



HEAVY STAMPING STRAIGHT SIDED POWER PRESSES



- Extended Die life
- Reduces Vibration and Noise
- Maintains high accuracy and high productivity
- Extra Rigid Heavy Duty Power Press

Long, eight-point slide guides and highly rigid frame construction assures high accuracy, thus maintaining long die life. And resulting in silent press performance minimized vibration and extended die life.

SBP Series

A SERIES

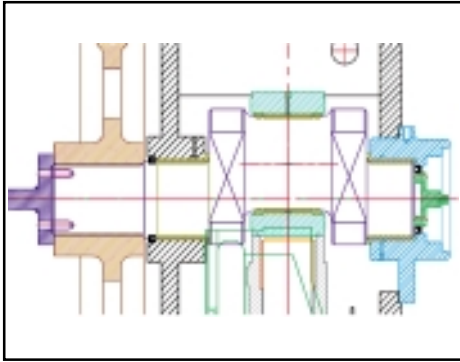

Crankshaft

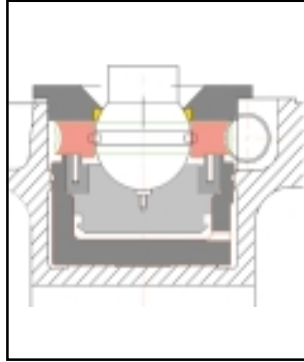

Ball Screw

B SERIES

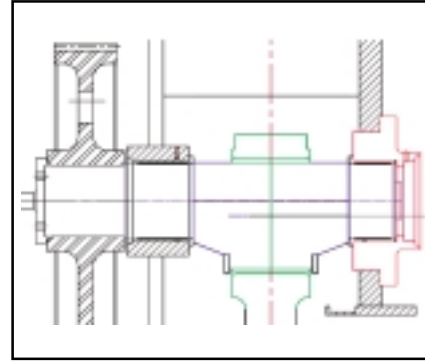

Eccentric Shaft

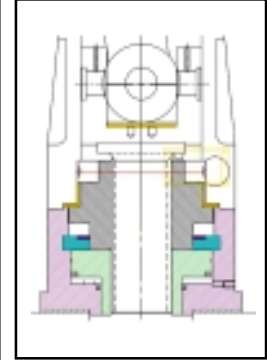

Wrist Pin

TECHNICAL SPECIFICATIONS

		SINGLE FRAME																					
MODEL		SBP-110				SBP-160				SBP-200				SBP-250				SBP-320		SBP-400	SBP-500		
		A		B		A		B		A		B		A		B		B	B				
		S	H	S	H	S	H	S	H	S	H	S	H	S	H	S	H	H	S	S	S		
CAPACITY	Tonne	110				160				200				250				320		400	500		
FIX STROKE	mm	160	70	160	70	200	80	200	80	220	90	220	90	250	100	250	100	110	300	300	350		
ADJUSTABLE STROKE	mm	8-125	8-70	-	-	8-160	-	-	-	-	-	-	-	-	-	-	-	-	-	-	-		
SPM(FIX)	SPM	50	80	50	80	40	80	40	80	35	65	35	65	30	55	30	55	50	25	22	18		
SPM (VARIABLE)	SPM	35-60	60-120	35-60	60-120	30-50	50-100	30-50	50-100	25-45	40-80	25-45	40-80	25-40	30-70	25-40	30-70	25-65	20-40	18-25	15-22		
RATING POINT	mm	5	3	5	3	6	3.5	6	3.5	6	3.5	6	3.5	6	4	6	4	4	7	8	9		
DIE HEIGHT	mm	400				450				450				500				550		600	650		
SLIDE ADJUSTMENT	mm	90		125		100		150		110		175		120		200		200		200			
SLIDE AREA	mm ²	800 X 700				800 X 750				1000 X 850				1100 X 900				1200 X 900		1300 X 1000		1400X1100	
BOLSTER AREA	mm ²	900 X 800				900 X 850				1100 X 950				1200 X 1000				1300 X 1000		1400 X 1100		1500X1200	
BOLSTER THICKNESS	mm	140				165				180				180				180		200		220	
FLOOR TO TOP OF BOLSTER	mm	900				900				950				950				950		950		950	
MAIN MOTOR (HP X P)	fix	10 x 4P				15 x 4P				20 x 4P				25 x 4P				30 x 4P		40 x 4P		50 x 4P	
	Variable	15 x 4P				20 x 4P				25 x 4P				30 x 4P				40 x 4P		50 x 4P		60 x 4P	

DIE CUSHION	BELLOW TYPE																	PISTON CYLINDER TYPE
	Tonne	8	8	10	10	14	14	14	14	28	28	40						
CAPACITY	Tonne	8	8	10	10	14	14	14	14	28	28	40						
STROKE	mm	90	90	100	100	110	110	120	120	140	150	180						
PAD AREA	mm	480x300	480x300	540x340	540x340	640x440	640x440	740x540	740x540	700x400	750 x 400	850 x 450						

* A > Crank shaft , Ball screw * B > Eccentric shaft , Wrist pin * S > Standard Geared * H > High Speed Geared

THE MANUFACTURER RESERVE RIGHTS TO MODIFY DESIGN, SPECIFICATIONS , MECHANISM, ETC. TO IMPROVE THE PERFORMANCE OF THIS MACHINE WITHOUT NOTICE.



scan for website

SINGHAL POWER PRESSES PVT. LTD.

CORP. OFFICE : 201-202, KARMA STAMBH INDUSTRIAL ESTATE, LBS MARG, NEAR HOME TOWN, 24/7, VIKHROLI (W), MUMBAI-400 083 TEL.: 67242000, 25784515 FAX : 91-22-25798809, 67969652

E-mail : info@singhal.co.in / info@sewpresses.com Web : www.sewpresses.com

PLANT:NH 8B, OPP. FIELD MARSHAL SCHOOL, SHAPAR, DIST. RAJKOT TEL:02827-252358, 253381 FAX:02827-253278

SALES OFFICES

BENGALURU :

603 - A, Mittal Tower, M. G. Rd., Bengaluru - 560 001
Tel.: 25587728
Telefax : 080-25594143

CHENNAI :

2-A, First Floor, 610, MTH Road, Padi, Chennai - 600 050.
Tel.: 43021245 & 43021246

FARIDABAD :

53, 1st Floor, Neelam Flyover Market, Faridabad -121001
Tel.: 0129-2420150

PUNE :

18, Soham Industrial Complex, Plot No. 318, Sector -10, Near Times of India, Bhosari, Chinchwad, Pune - 411 010 Tel.: 9619421286